

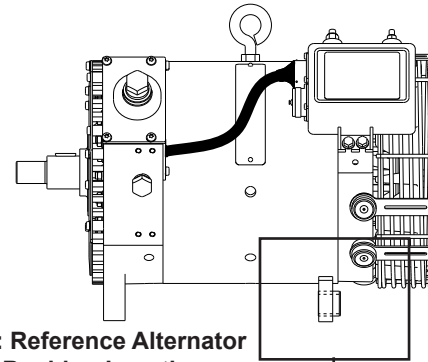

**Topic:** Resetting split bushings in hinge mount alternators for reinstallation or alternate mounting options  
**Alternators Affected:** All hinge mount alternators with split bushing

**Issue Date:** 03/30/2023  
**Document Number:** SB48

CEN hinge mount alternators use a split bushing in one of the mounting feet to adjust for mounting bracket tolerances to ensure a secure, tight fit when mounted on engine bracket. These alternators are shipped from the factory with the split bushing flush with the inside face of the mounting foot it is installed in. Some alternator mounting brackets may require the bushing to be shifted to the opposite face of the mounting foot. Follow instructions below to ensure proper adjustment of split bushing. See Figure 1 for typical alternator split bushing location.



**Figure 1: Reference Alternator  
Split Bushing Location**

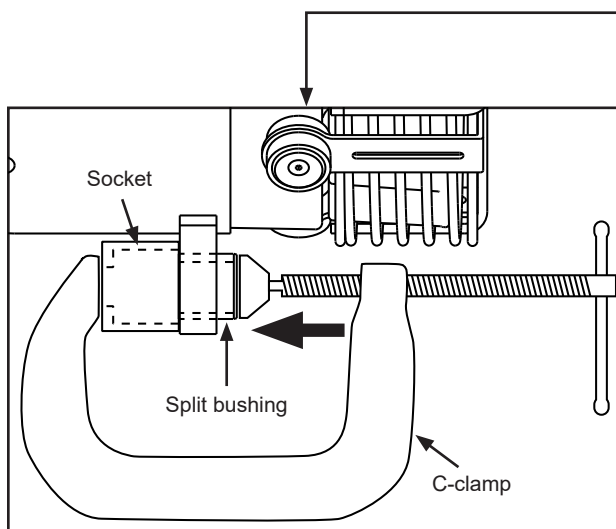

**Figure 2: Method 1 (C-clamp)**

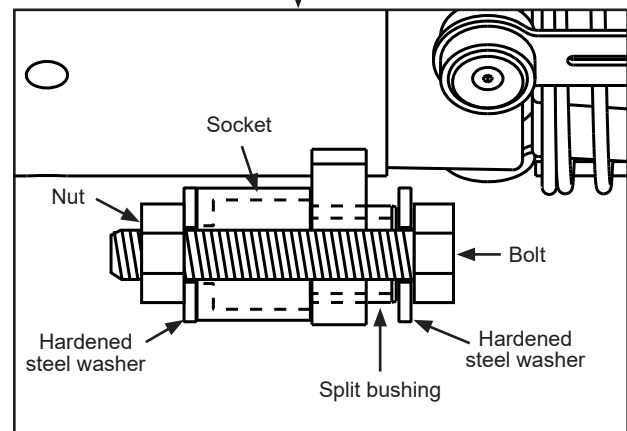

**Figure 3: Method 2 (Nut and Bolt)**

### Method 1: C-clamp

1. Find a C-clamp and a socket with an ID larger than the split bushing OD and deep enough to accept the whole length of the split bushing.
2. Center the open side of the socket on the side of the alternator foot that does not have the split bushing protruding as shown in Figure 2.
3. Position the C-clamp so that the socket and split bushing are centered between both of the C-clamp jaws.
4. Tighten C-clamp until split bushing is flush with the alternator mounting foot.

### Method 2: Nut and Bolt

1. Find a socket with an ID larger than the split bushing OD. Find a bolt long enough to go through the bushing and socket when assembled as shown in Figure 3.
2. Assemble the socket with bolt, nut, and two hardened steel flat washers as shown in Figure 3.
3. Hold the bolt head with a wrench and tighten the nut until the split bushing is flush with the alternator mounting foot.

**Please file this CEN Service Bulletin with your CEN Literature.  
Please forward a copy of this information to the appropriate people in your company.**